

Decision Rules and their Application to Meeting the Requirements of ISO/IEC 17025:2017

Friday, September 20, 2019 – 1:00pm EST

Presented by:

Michael Kramer

PJLA Calibration /Inspection Program Manager

mkramer@pjlabs.com

Pass/Fail Guard-Band with 95% Expanded Uncertainty

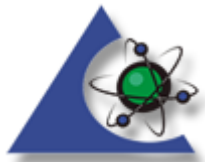
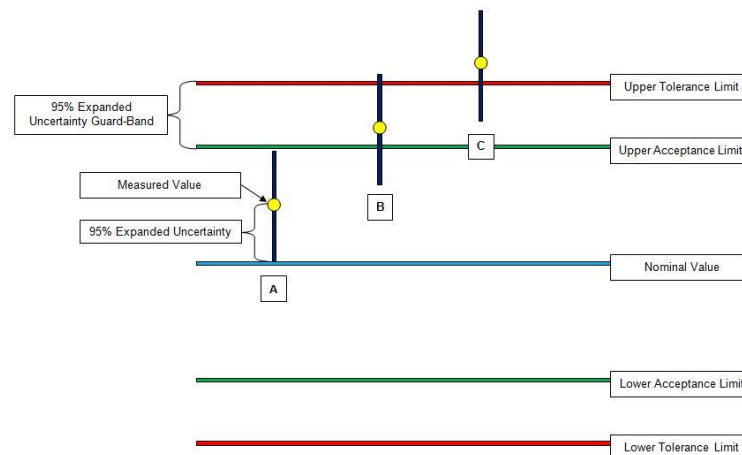

Decision Rules and their Application to Meeting the Requirements of ISO/IEC 17025:2017

This webinar is being recorded and will be available in it's entirely on the Perry Johnson Laboratory Accreditation Website.

Webinar slides are now available for downloading

www.pjlab.com

Go to the link for recorded webinars.

Duration of webinar is set for one hour.

You can type any questions directly into your webinar box; We will review them at the conclusion of today's session; Please keep question presented related to the topic of today's webinar.

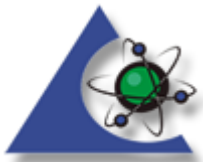

Statements of Conformity and the Decision Rule

3.7

decision rule

rule that describes **how** measurement uncertainty is accounted for when stating conformity with a specified requirement

From ISO/IEC 17025:2005

5.10.4.2

When statements of compliance are made, the uncertainty of measurement shall be taken into account.

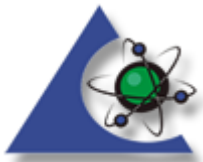

Statements of Conformity and the Decision Rule

Statement of conformity and the decision rule first appears in ISO/IEC 17025:2017 under “Review of Request Tenders and Contracts.

7.1.3 When the customer requests a statement of conformity to a specification or standard for the test or calibration (e.g. pass/fail, in-tolerance/out-of-tolerance), **the decision rule** shall be clearly defined. Unless inherent in the requested specification or standard, the decision rule selected shall be communicated to, and agreed with, the customer. **The key here is “when it is requested” which implies it is requested by the customer. •This means that “contract review” must take place and a clear definition agreed on BEFORE the job is started**

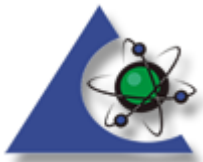

Statements of Conformity

*Can there be a default decision rule. Take it or leave it.
Question? Does this constitutes an agreement?*

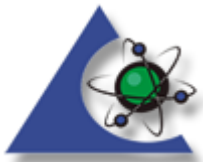

Statements of Conformity and the Decision Rule

Laboratories need to be flexible and if they have the capabilities meet the requirements of the customers. This is specified in other parts of the Standard.

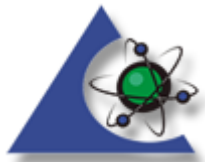

Customer Requirements



Pipette used in DNA Testing in Crime Lab



Pipette used to test drinking water



Pipette used in chemistry class (rough estimation)

Is the level of risk of false acceptance the same?

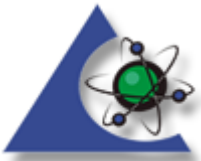

Meeting Customer Requirements

7.1 Review of requests, tenders and contracts

7.1.1 The laboratory shall have a procedure for the review of requests, tenders and contracts. The procedure shall ensure that:

d) the appropriate methods or procedures are selected and are capable of meeting **the customers' requirements**

7.1.7 The laboratory shall **cooperate with customers** or their representatives in clarifying the customer's request and in monitoring the laboratory's performance in relation to the work performed.

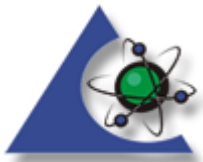

Meeting Customer Requirements

Structural Requirement

5.4 Laboratory activities shall be carried out in such a way as to meet the **requirements** of this document, the laboratory's **customers**, regulatory authorities and organizations providing recognition

5.7 Laboratory management shall ensure that:

- a) communication takes place regarding the effectiveness of the management system and the importance of meeting **customers'** and other **requirements**

Reporting the Results

7.8.1.2 Shall include all the information **agreed with the customer** and necessary for the interpretation of the results and all information required by the method used.

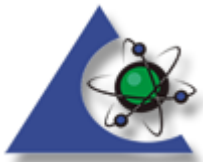

Statements of Conformity and the Decision Rule

Risk may be a key factor for customers which operates under ISO/IEC 17025:2017 and ISO 9001:2015

9001:2015

Section 6.1 Actions to Address Risks and Opportunities

Actions taken to address risks and opportunities shall be proportionate to the potential impact on the conformity of products and services.

ISO/IEC 17025:2017

8.5.1 The laboratory shall consider the risks and opportunities associated with the laboratory activities in order to:

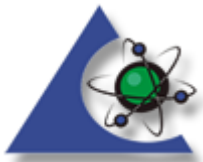

ILAC-G8:09/2019 Guidelines on Decision Rules and Statements of Conformity

This guidance document has been prepared to assist laboratories in the use of decision rules when declaring statements of conformity to a specification or standard as required by ISO/IEC 17025:2017

The revised ISO/IEC 17025:2017 recognizes that no single decision rule can address all statements of conformity across the diverse scope of testing and calibration

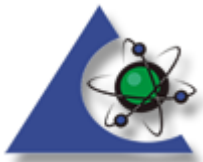
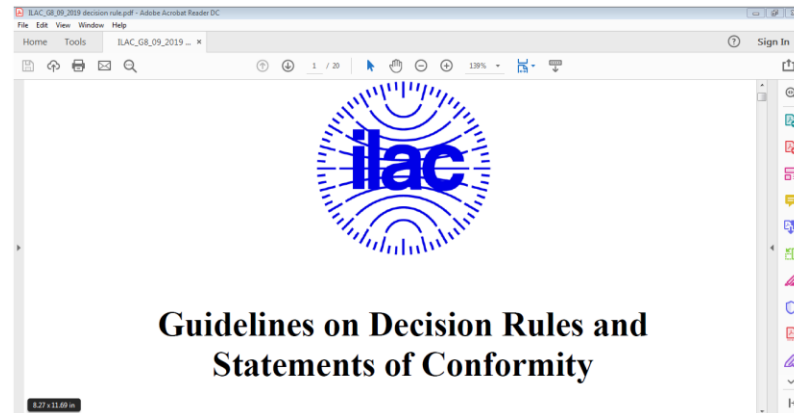

ILAC-G8:09/2019 Guidelines on Decision Rules and Statements of Conformity

Guard Band (w) interval between a tolerance limit and a corresponding acceptance limit where length $w=|TL-AL|$.

Simple Acceptance a decision rule in which the acceptance limit is the same as the tolerance limit, i.e. $AL=TL$

Test Uncertainty Ratio (TUR) the ratio of the tolerance, TL , of a measurement quantity, divided by the 95% expanded measurement uncertainty of the measurement process where $TUR = TL/U$.

ILAC G documents available at:

<https://ilac.org/publications-and-resources/ilac-guidance-series/>

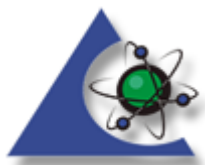

Statements of Conformity and the Decision Rule

ISO/IEC 17025:2017 includes criteria related to decision rules and conformity with requirements in resources and processes related to personnel, contract review and reporting as described below

Clause 3.7: a decision rule is defined as “*a rule that describes how measurement uncertainty will be accounted for when stating conformity with a specified requirement*”

Authorized Personnel

Clause 6.2.6 requires that the laboratory shall authorize personnel to perform “*analysis of results, including statements of conformity or opinions and interpretations*”.

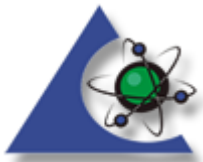

Decision Rule “Reporting”

Clause 7.8.6.1 states *“When a statement of conformity to a specification or standard for test or calibration is provided, the laboratory shall document the decision rule employed, taking into account the level of risk (such as false accept and false reject and statistical assumptions) associated with the decision rule employed and apply the decision rule.”*

Clause 7.8.6.2 requires that *“the laboratory shall report on the statement of conformity, such that the statement clearly identifies:*

- a) to which results the statement of conformity applies;*
- b) which specifications, standard or parts thereof are met or not met;*
- c) the decision rule applied (unless it is inherent in the requested specification or standard).”*

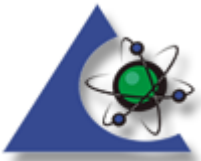

Statements of Conformity

7.8.6.2c state the following

the laboratory shall report on the statement of conformity, such that the statement clearly identifies

the decision rule applied (unless it is inherent in the requested specification or standard).”

Unless it is inherent in the requested specification or standard;

So what does this mean?

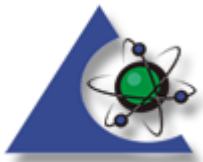

Statements of Conformity

There are testing methods that determine how the rules are applied. One good, common illustration is ASTM E18 for Rockwell Hardness where the testing and calibration decision rules take uncertainty into account effectively in the repeat testing and other "limits" as to the spread of the data etc. and the rules are defined in the method.

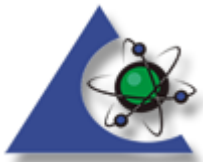

Statements of Conformity

Another is ASTM A29 for Standard Specification for General Requirements for Steel Bars, Carbon and Alloy Hot-Wrought where it has an auxiliary table that is based on the method uncertainty to give some "extra" room to make a decision.

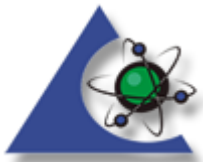

Statements of Conformity

From ILAC-G8:09/2019

If your application already has measurement decision rules governed by a published standard guidance document. (Examples: ISO 14253, ISO 8655, ISO 6508, etc). Generally, in these cases, standard test methods are prescribed and often compliance limits already have a guard band built in to the limit, so any further guard banding to limit risk is not necessary

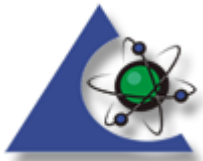

Statements of Conformity

Decision rules for proving conformance or non-conformance with specifications makes a differentiation whether conformance or non-conformance shall be determined with a high probability. The expanded measurement uncertainty U and a confidence level of approx. 95% (expansion factor $k = 2$) will generally be considered to be adequate. There may be cases that would require a higher confidence level of e.g. 99% (expansion factor $k = 3$) be chosen

Here is your coverage factor.

Confidence	<input type="text" value="95"/>
probability	<input type="text" value="0.05"/>
df	<input type="text" value="19"/>
t value	<input type="text" value="2.093"/>

Coverage Factor (k)

99.73
0.0027

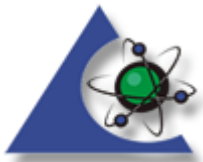

Statements of Conformity

Where the measurement uncertainty interval is overlapping the limit value, implies a careful analysis that should establish objective criteria (decision rule) to accept the measurement having part of the uncertainty interval outside the tolerance ;

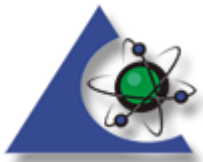
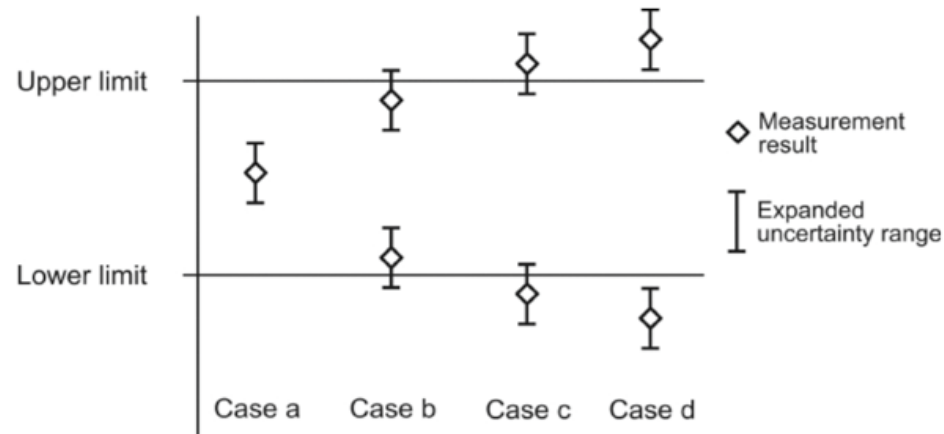

Binary Statement for Simple Acceptance Rule ($w=0$)

A binary decision rule exists when the result is limited to two choices (pass or fail)

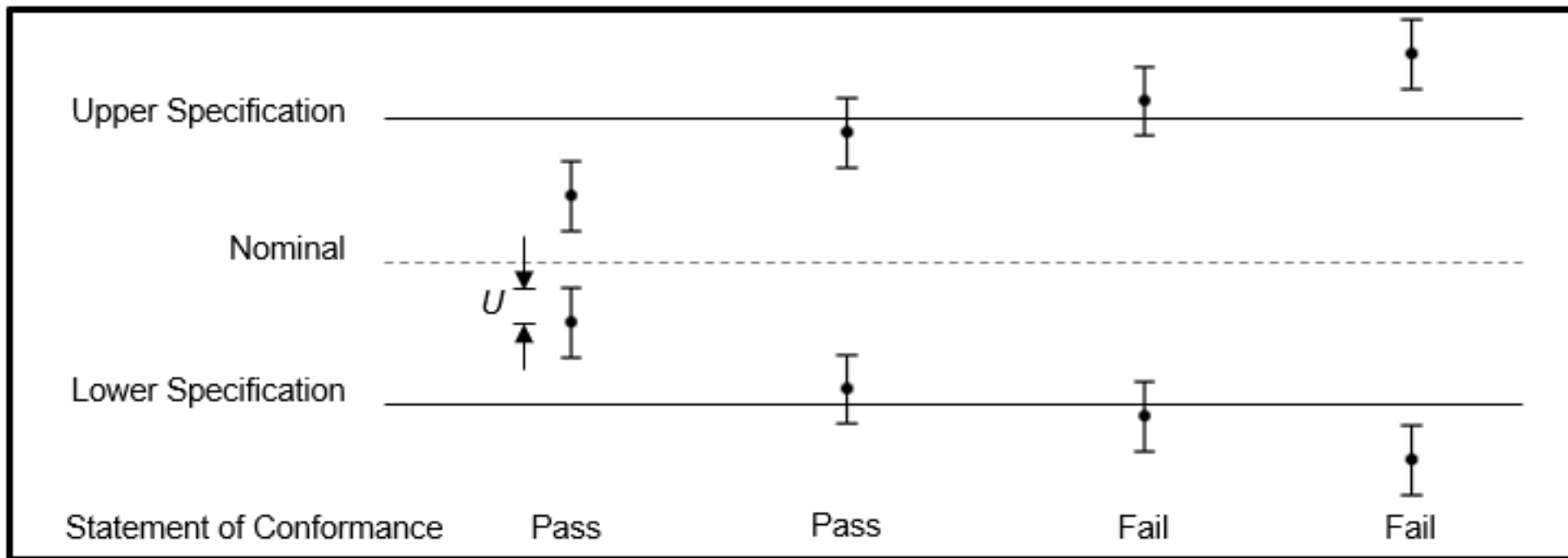

$U = 95\%$ expanded measurement uncertainty

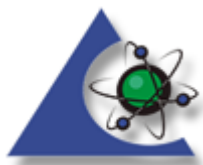

Binary Statement with Guard Band

4.2.2 Binary Statement with Guard Band

Statements of conformity are reported as:

- Pass - acceptance based on guard band; the measurement result being below the acceptance limit, $AL = TL - w$.
- Fail - rejection based on guard band; if the measurement result is above the acceptance limit, $AL = TL - w$

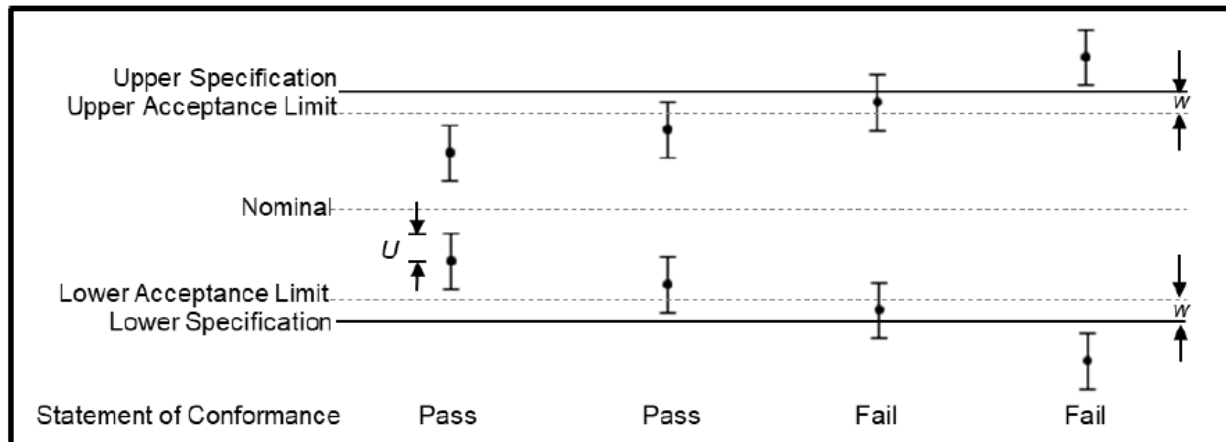

$U = 95\%$ expanded measurement uncertainty

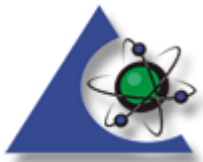

Non-binary Statement with Guard Band

non-binary decision rule exists when multiple terms may express the result (pass, conditional pass, conditional fail, fail).

4.2.3 Non-binary Statement with Guard Band

Statements of conformity are reported as:

- Pass - the measured result is below the acceptance limit, $AL = TL - w$.
- Conditional Pass - the measured result is inside the guard band and below the tolerance limit, in the interval $[TL - w, TL]$.
- Conditional Fail - the measured result is above the tolerance limit but below the tolerance limit added to the guard band, in the interval $[TL, TL + w]$.
- Fail - the measured result is above the tolerance limit added to the guard band, $TL + w$.

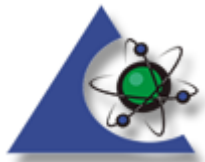
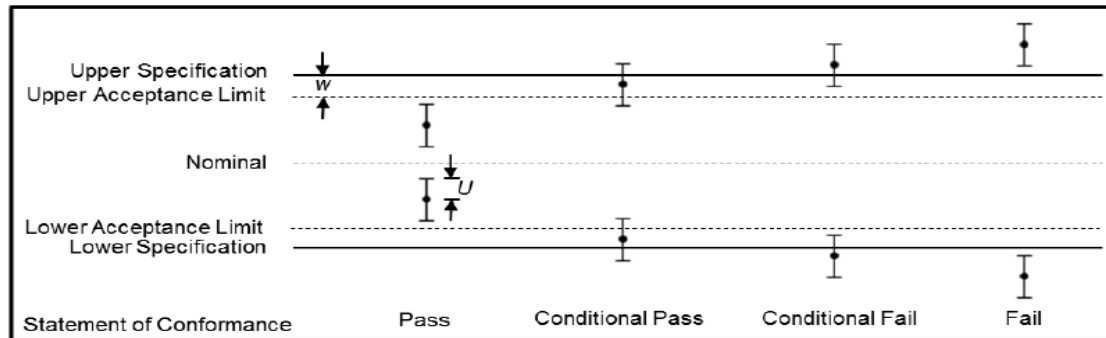

Examples of Decision Rules ILAC-G8:09/2019

Example 1 Simple acceptance (choice a in figure 7)

The customer agrees that Pass/Fail decisions are based on acceptance limits chosen based on simple acceptance ($w = 0, AL = TL$). The expanded measurement uncertainty calculated per the GUM must be less than 1/3 of the tolerance limits based on the manufactures specifications ($TUR > 3:1$). Statements of conformity are binary. The estimate of the measurand is assumed to have a normal probability distribution and specific risk is used for the risk calculation. In this case, the risk that accepted items are outside the tolerance limit is up to 50%. The risk of false reject is up to 50%¹ for measured results outside the tolerance.

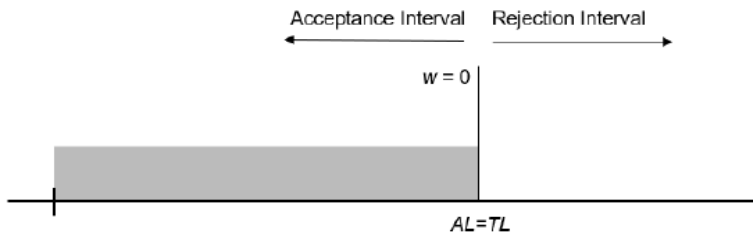

Statements of conformity are reported as:

- Passed - The measured values were observed in tolerance at the points tested.
- Failed - One or more measured values were observed out of tolerance at the points tested.

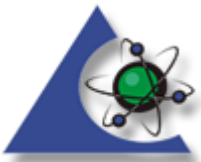

Examples of Decision Rules ILAC-G8:09/2019

ILAC_G8_09_2019 decision rule.pdf - Adobe Acrobat Reader DC

File Edit View Window Help

Home Tools ILAC_G8_09_2019 ... x ISO/IEC 17025:201... Statements of Conf... ? Sign In

18 / 20 150%

Example 2 Non-binary acceptance based on guard band $w = U$ (choice b in figure 7)

The customer agrees that decisions are based on guard banded acceptance limits. ($w = U$, $AL = TL - w$) where U is the expanded measurement uncertainty calculated per the GUM. Statements of conformity are non-binary. The estimate of the measurand is assumed to have a normal probability distribution and specific risk is used for the risk calculation. In this case the risk of accepted items to be outside the tolerance limit is $< 2.5\%$. For rejected items the risk to be inside the tolerance limit is $< 2.5\%$. When the measured result is close to the tolerance, the risk of false accept and false reject is up to 50%.

Acceptance Interval Conditional Pass Conditional Fail Rejection Interval

Guard band

$w = U$

AL TL TL+w

8.27 x 11.69 in

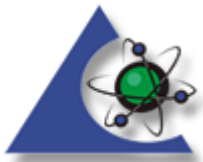

Examples of Decision Rules ILAC-G8:09/2019

Example 2 continued

Measurement results are reported as:

- Pass - The measured values were observed in tolerance at the points tested. The specific false accept risk is up to 2.5%.
- Conditional Pass - The measured values were observed in tolerance at the points tested. However, a portion of the expanded measurement uncertainty intervals about one or more measured values exceeded tolerance. When the measured result is close to the tolerance, the specific false accept risk is up to 50%.

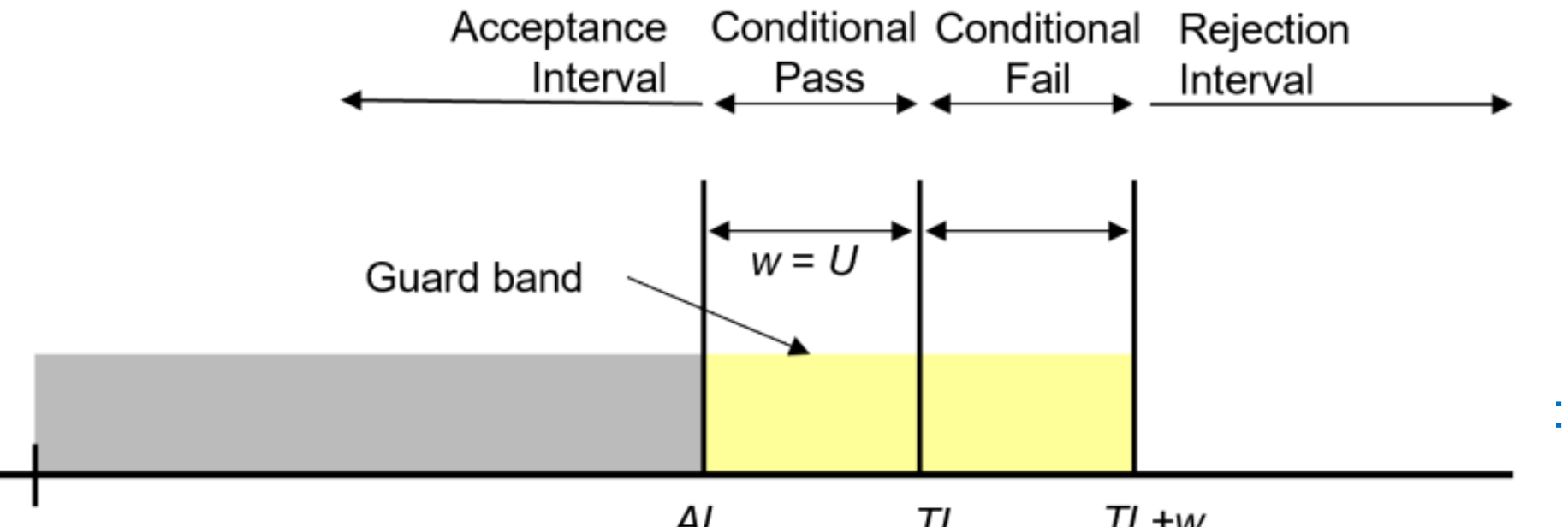

Examples of Decision Rules ILAC-G8:09/2019

Example 2 continued

Conditional Fail- One or more measured values were observed out of tolerance at the points tested. However, a portion of the expanded measurement uncertainty intervals about one or more measured values were in tolerance. When the measured result is close to the tolerance, the specific false reject risk is up to 50%.

- Fail - One or more measured values were observed out of tolerance at the points tested. The specific false reject risk is up to 2.5%.

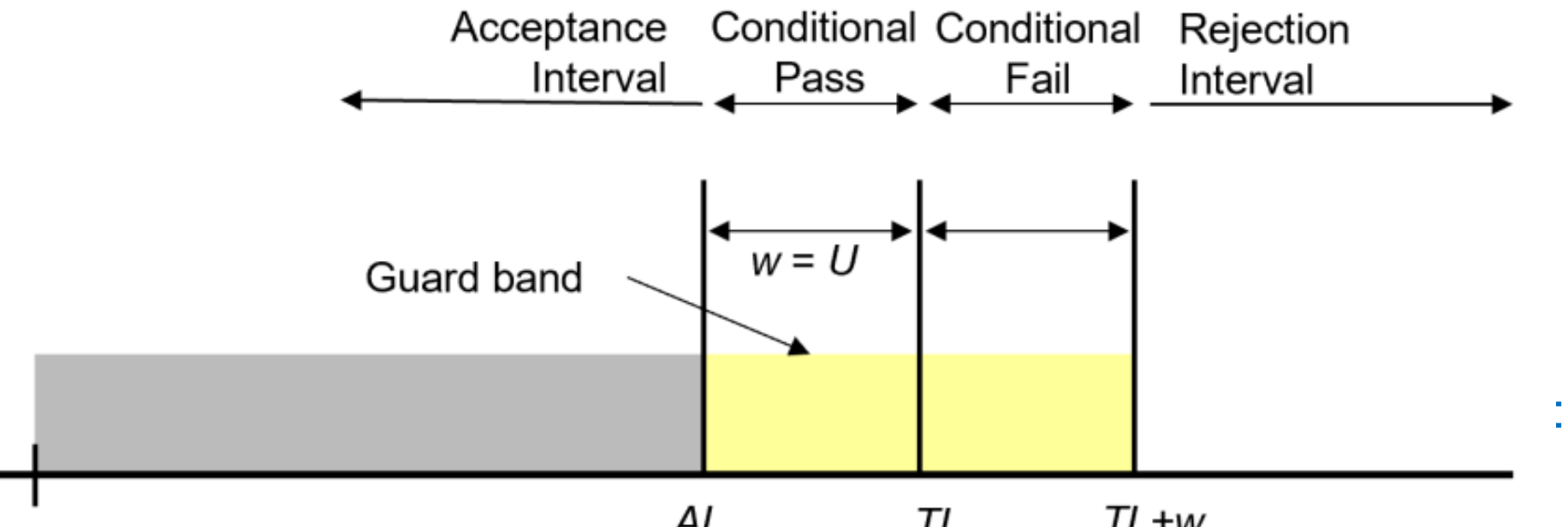

Common Decision Rules Examples

Based on the previous models, and if accepted by the customer as per the requirements specified in 7.1.3, the following decision rules can be documented:

Accounting for the uncertainty will be taken to mean that at a 95% confidence level the measurement result plus and minus the expanded uncertainty ($k=2$) shall be totally within the specification limits and the risk of false acceptances/rejection will not be greater than 5%

Or

The result cannot be reported as being in specification if the risk of false acceptance/rejection to the customer is greater than 5%.

7.8.6.1 When a statement of conformity to a specification or standard is provided, the laboratory shall document the decision rule employed, **taking into account the level of risk** (such as false accept and false reject and statistical assumptions) associated with the decision rule employed, and apply the decision rule.



Statements of Conformity

There may also be cases where the uncertainty and the decision rule for taking uncertainty into account is not required,

7.8.1.3 When **agreed** with the customer, the results may be reported in a simplified way. Any information listed in 7.8.2 to 7.8.7 that is not reported to the customer shall be readily available



From ISO/IEC 17025:2005

In the case of tests or calibrations performed for internal customers, or in the case of a **written agreement** with the customer, the results may be reported in a simplified way



Statements of Conformity



This time is allocated for answering questions. You should have a space provided for submitting questions.

Please keep questions related to the topic covered in this webinar;

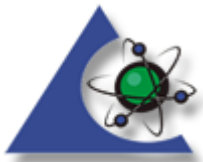

Save the Date

Next PJLA Webinar

Friday October 25 – 1:00pm EST



ISO/IEC 17025;2017, Section 4.1 Impartiality and 4.2
Confidentiality

